

DATASHEET

HMAG PRO HYDRAULIC MAGNET - DSMART MODELS



Aggregate und Werkzeuge

www.kw-hydraulik.de info@kw-hydraulik.de +49 3675 421 980

HMAG PRO 700
HMAG PRO 900
HMAG PRO
1200



HMAG PRO HYDRAULIC MAGNET - DSMART MODELS

TABLE OF CONTENTS

v.2.0 02/2024 WNu

1. DSMART MODELS	3
1.1 DIMENSIONS	3
1.2 CONNECTIONS	3
1.3 TECHNICAL SPECIFICATIONS	4

1. DSMART MODELS

1.1 DIMENSIONS

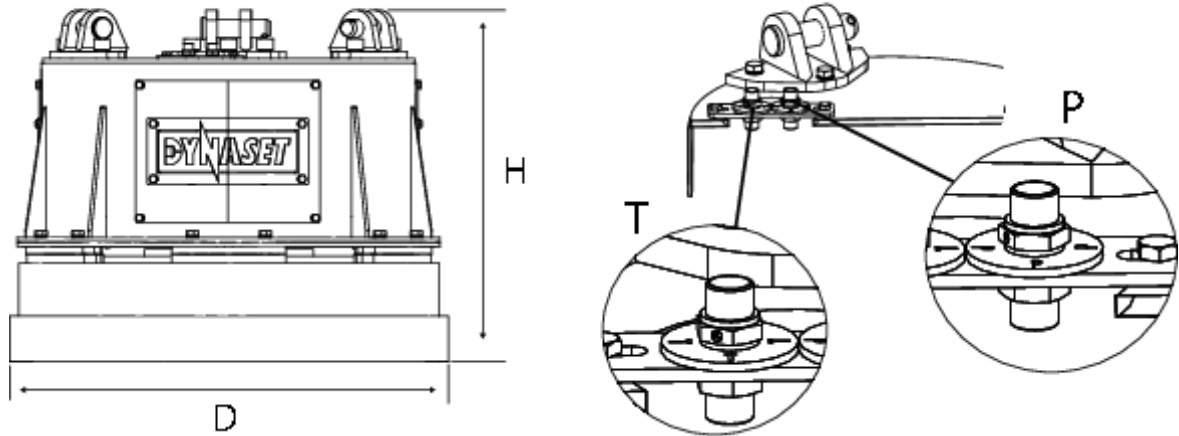

Model	Dimensions, mm (in)		Weight
	Diameter, D	Height, H	
HMAG PRO 700-18	750 (29.5)	632 (24.9)	450 (993)
HMAG PRO 900-30	960 (37.8)	767 (30.2)	900 (1,987)
HMAG PRO 1200-41	1,260 (49.6)	828 (32.6)	1,550 (3,422)

Notice! Measurements may change if optional accessories are installed.

1.2 CONNECTIONS

Model	Connections	
	Pressure Line, P	Returnline, T
HMAG PRO 700-18	BSPP 1/2	BSPP 1/2
HMAG PRO 900-30	BSPP 1/2	BSPP 1/2
HMAG PRO 1200-41	BSPP 1/2	BSPP 1/2



HMAG PRO HYDRAULIC MAGNET - DSMART MODELS

DSMART MODELS

1.3 TECHNICAL SPECIFICATIONS

		HMAG PRO 700-18	HMAG PRO 900-30	HMAG PRO 1200-41
OUTPUT CHARACTERISTICS				
Generator Power max.	kW	3	6	10
Magnet coil power max.	kW	2.7	5.5	9.5
Magnet coil resistance (20 °C)	Ohm	16.1±5%	9.8±5%	5.4±5%
Operating voltage	V	220±5%	220±5%	220±5%
Efficient duty rating	ED%	60	60	60
NOMINAL LIFTING CAPACITY				
Tear-off w/ air gap Ø/300	kg (lbs)	5,500 (12,141)	10,500 (23,179)	15,000 (33,113)
Slabs, blocks	kg (lbs)	2,700 (5,960)	5,250 (11,589)	7,500 (16,556)
Cast iron pigs	kg (lbs)	105 (232)	230 (508)	410 (905)
Scrap,	grade 3A	80 (177)	200 (442)	370 (817)
Scrap,	grade 24	70 (155)	190 (419)	360 (795)
Scrap,	grade 40	40 (88)	100 (221)	190 (419)
HYDRAULIC POWER REQUIREMENTS				
Flow min.	l/min (gpm)	21 (5.55)	32 (8.45)	46 (12.15)
Required system pressure min.	bar (psi)	200 (2,901)	160 (2,321)	215 (3,118)
Pressure max.	bar (psi)	350 (5,076)	350 (5,076)	350 (5,076)
HYDRAULIC FLUID REQUIREMENTS				
Viscosity	cSt	10-200/ 25-35	10-200/ 25-35	10-200/ 25-35
Temperature max.	°C(°F)	70 (158)	70 (158)	70 (158)
Filter ratio	µm	25	25	25
Cooling capacity requirements	KW	1.4	2.4	3.1
Gallons are U.S. liquid gallons				



**HMAG PRO HYDRAULIC MAGNET - DSMART MODELS
DSMART MODELS**



Menotie 3
FI-33470 Ylöjärvi, Finland
tel: +358 3 3488 200
info@DYNASET.com



ELECTRICITY

HG Hydraulic Generator
HGV POWER BOX Variable Hydraulic
Generator System
HGV Variable Hydraulic Generator System
HWG Hydraulic Welding Generator
HGG Hydraulic Ground Power Generator



HIGH PRESSURE WATER

HPW Hydraulic High Pressure Water Pump
HPW Hydraulic Power Washer
KPL High Pressure Street Washing Unit
KPL-WEED Weed Killing Unit
SCU Surface Cleaning Unit
HPW-DUST High Pressure Dust Suppression
System
PPL High Pressure Pipe Cleaning Unit
HPW-FIRE High Pressure Firefighting System
FP Fire Fighting Piercing Kit
HDF Hydraulic Drilling Fluid Pump
JPL High Pressure Bin Washing System
HSP Hydraulic Submersible Pump



COMPRESSED AIR

HK Hydraulic Piston Compressor
HKL Hydraulic Rotary Vane Compressor
HKR Hydraulic Screw Compressor



MAGNET POWER

HMG PRO Hydraulic Magnet Generator
MAG Lift Magnet
HMAG PRO Hydraulic Magnet



VIBRATION

HVB Hydraulic Vibration Pump
HVD Hydraulic Directional Vibra
HRC Hydraulic Reversal Cylinder



POWER BOOSTING

HPI Hydraulic Pressure Intensifier
HPI-C Hydraulic Pressure Intensifier for
Cylinder



VACUUM

HCF Hydraulic Centrifugal Fan
HRVB Hydraulic Recycling Vacuum Bucket



KNOW-HOW

Hydraulic Power Take-off (PTO)
Hydraulic Power Unit Technology
HEU Hydraulic Expansion Unit
HRU Hydraulic Rescue Units
De-Icing Technology
Installation Valves
HHK Hydraulic Grinder
HV/HVY Hydraulic Winch / Winch Unit

www.DYNASET.com



/dynaset



/dynasetoy



/Dynaset_ofcl



/dynaset_official