

P-300

Hydraulischer Presskopf Hydraulic Crimping Head

High-End-Modell in unserer neu entwickelten Reihe von hydraulischen Pressköpfen

- ☉ Stabile und Kompakte Konstruktion
- ☉ Zum Anschluss an eine Hydraulikpumpe für einfachwirkende Werkzeuge
- ☉ 245 kN bei 700 bar
300 kN bei 850 bar
- ☉ Hub: 24 mm
- ☉ Einsätze Ø60mm

High-end model in our newly designed range of hydraulic crimping heads

- ☉ Light weight and compact design
- ☉ For the connection to a hydraulic pump for single acting tools
- ☉ 245 kN at 10.000 PSI
300 kN at 12.142 PSI
- ☉ Stroke: 24 mm
- ☉ Dies Ø60mm



Presseinsätze / Crimping die



Einsatzführung / Insert guide



Typ Type	Presskraft Press Power kN	Kupfer DIN Copper DIN mm ²	Aluminium Aluminum mm ²	Abmessung Dimension mm	Gewicht Weight kg
P-300	245 kN @ 700 bar 300 kN @ 850 bar	630	500	260x135xH115	6

P-230 / P-300

Presseinsätze Serie D60

Crimping dies series D60

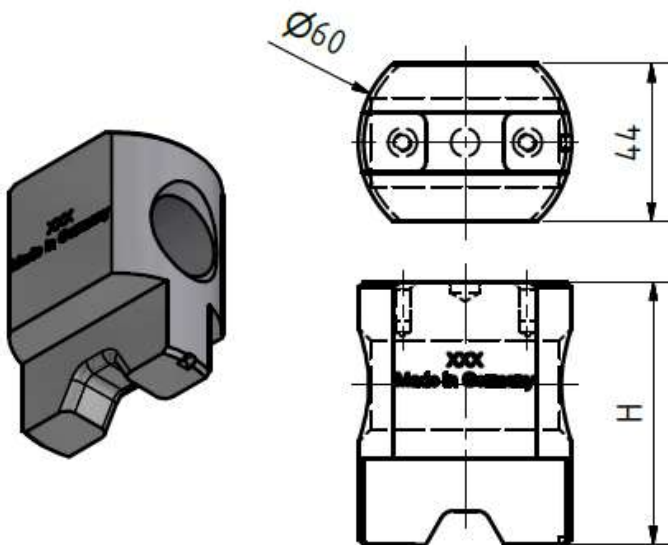

OT
 Außenmaße: Ø60
 Breite: 44
 Höhe: 70 bis 73,8
 Bohrung: Ø25

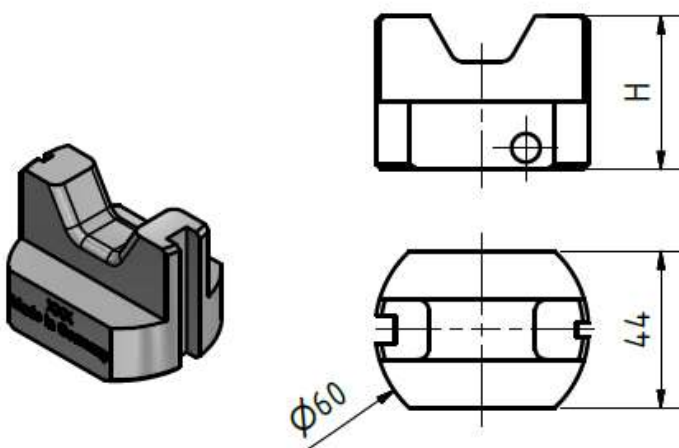

UT
 Außenmaße: Ø60
 Breite: 44
 Höhe: 30 bis 43
 Bohrung: keine

Gewicht / Weight: ~1500 g

P-230/P-300/G-III

Presseinsätze Serie D60 (Ø60mm)

Crimping dies series D60 (Ø60mm)

- Sechskant-Preßeinsätze nach DIN 48083
 - Kupfer Presskabelschuhe (DIN46235)
 - Kupfer Verbinder nach (DIN 46267, Teil 1)
 - Aluminium Presskabelschuhe und Verbinder nach DIN AL und DIN AL/CU
 - Pressverbinder für zugfeste Verbindungen von ALDREY-Seilen nach DIN EN 50182
 - AL-Leiter nach DIN EN 50182
 - Pressverbinder nach DIN 48085, Teil 3 für AL/Stahl-Seile nach DIN EN 50182
 - Aluminiumhülsen-Verpressung
 - Pressverbinder nach DIN 48085, Teil 3 für AL/Stahl-Seile nach DIN EN 50182
 - Stahlhülsen-Verpressung
- Hexagonal crimping dies according DIN 48083
 - Copper compression cable lugs (DIN46235)
 - Copper connectors (DIN 46267, part 1)
 - Aluminum compression cable lugs and connectors to DIN
 - Compression joints for all full tension connectors of ALDREY conductors acc. to DIN EN 50182
 - AL-conductors acc. to DIN EN 50182
 - Compression joints acc. to DIN 48085, part 3 for AL/Steel-cables (ACSR) acc. to DIN EN 50182 – Aluminium compression
 - Compression joints acc. to DIN 48085, part 3 for AL/Steel-cables (ACSR) acc. to DIN EN 50182 – Steel crimping



Typ Type	Kennzahl Size code	Pressbreite Crimping width	Kupfer DIN zugentlastet Copper DIN non-tension	Kupfer DIN zugfest Copper DIN full-tension	Aluminium zugentlastet Aluminium non-tension	Aluminium zugfest Aluminium full-tension	Aluminium-Hülse Aluminium sleeve	Stahl-Hülse Steel sleeve	Aldreiseil Aldrey cable
		mm	mm ²	mm ²	mm ²	mm ²	mm ²	mm ²	mm ²
PK9-D60-B14	9	14	---	---	---	---	---	12-15	---
PK10-D60-B14	10	14	25	25	10	---	---	---	---
PK11-D60-B14	11	14	---	---	---	---	---	25zf	---
PK12-D60-B14	12	14	35	35	16 + 25	16 + 25	16/2,5 25//4	---	25
PK13-D60-B14	13	14	---	---	---	---	---	16-29	---
PK14-D60-B14	14	14	50	50	35	35	35/6	---	---
PK15-D60-B14	15	14	---	---	---	---	---	30-40	---
PK16-D60-B14	16	14	70	70	50	50	50/8	---	---
PK17-D60-B14	17	14	---	---	---	---	---	41-50	---
PK18-D60-B14	18	14	95	---	70	70	70/12	---	70
PK19-D60-B14	19	14	---	---	---	---	---	51-56	---

P-230/P-300/G-III
Presseinsätze Serie D60 (Ø60mm)
Crimping dies series D60 (Ø60mm)

CU DIN



AL DIN

 AL/ST
ACSR

ALDREY



Typ Type	Kennzahl Size code	Pressbreite Crimping width	Kupfer DIN zugentlastet Copper DIN non-tension	Kupfer DIN zugfest Copper DIN full-tension	Aluminium zugentlastet Aluminum non-tension	Aluminium zugfest Aluminum full-tension	Aluminium-Hülse Aluminum sleeve	Stahl-Hülse Steel sleeve	Aldreyseil Aldrey cable
			mm ²	mm ²	mm ²	mm ²	mm ²	mm ²	mm ²
PK20-D60-B14	20	14	120	95	---	---	---	---	95
PK21-D60-B14	21	14	---	---	---	---	---	57-75	---
PK22-D60-B14	22	14	150	120	---	---	---	---	---
PK22-D60-B40	22	14	---	---	95 + 120	95	95/15	---	---
PK23-D60-B14	23	14	---	---	---	---	---	76-92	---
PK25-D60-B14	25	14	185	150	---	---	---	---	---
PK25-D60-B40	25	40	---	---	150	120	44/32 50/30 120/20	120	120
PK27-D60-B14	27	14	---	---	185se	---	---	---	---
PK28-D60-B14	28	14	240	---	---	---	---	---	---
PK28-D60-B40	28	40	---	---	185	150 185	125/30 150/25	---	150 185
PK30-D60-B17	30	17	---	185	---	---	---	---	---
PK30-D60-B25	30	25	---	---	---	---	95/55 170/40 185/30	---	---
PK32-D60-B17	32	17	300	---	---	---	---	---	---
PK32-D60-B25	32	25	---	---	240	---	---	---	---
PK34-D60-B17	34	17	---	240	---	---	---	---	---
PK34-D60-B25	34	25	---	---	300	240	99/72 105/75 120/40 210/35 210/50 230/30 240/40	---	---

P-230/P-300/G-III
Presseinsätze Serie D60 (Ø60mm)
Crimping dies series D60 (Ø60mm)



CU DIN



AL DIN

 AL/ST
ACSR

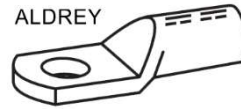
ALDREY



Typ Type	Kennzahl Size code	Pressbreite Crimping width mm	Kupfer DIN zugentlastet Copper DIN non-tension mm ²	Kupfer DIN zugfest Copper DIN full-tension mm ²	Aluminium zugentlastet Aluminum non-tension mm ²	Aluminium zugfest Aluminum full-tension mm ²	Aluminium-Hülse Aluminum sleeve mm ²	Stahl-Hülse Steel sleeve mm ²	Aldreyseil Aldrey cable mm ²
PK38-D60-B17	38	17	400	---	---	---	---	---	---
PK38-D60-B25	38	25	---	---	400	300	99/72 105/75 120/40 210/35 210/50 230/30 240/40	---	---
PK42-D60-B17	42	17	500	---	---	---	---	---	---
PK42-D60-B25	42	25	---	---	400*	---	380/50 385/35	---	---
PK44-D60-B17	44	17	625	---	500	---	---	---	---